

**SECTION A**

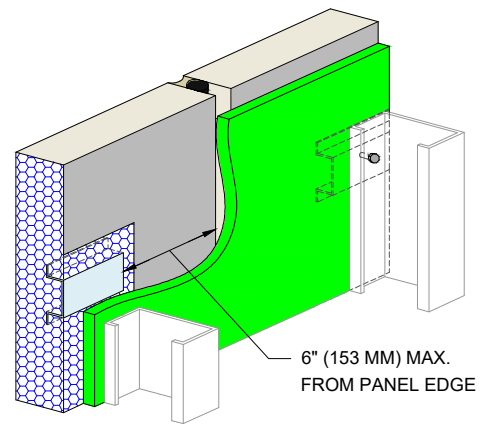

**BACK VIEW**

**NOTES:**

1. DRYVIT RECOMMENDS THAT GROUND FLOOR APPLICATIONS AND ALL FACADES EXPOSED TO ABNORMAL STRESS, HIGH TRAFFIC, OR DELIBERATE IMPACT HAVE THE BASE COAT REINFORCED WITH PANZER® MESH PRIOR TO STANDARD OR STANDARD PLUS MESH. LOCATION OF HIGH IMPACT ZONES SHOULD BE INDICATED ON CONTRACT DRAWINGS.
2. REFER TO DRYVIT PUBLICATION DS840 FOR AWRB AND FLASHING APPLICATION
3. MECHANICAL ATTACHMENTS ARE NECESSARY TO SUPPORT THE PANEL UNTIL THE ADHESIVE CURES. REFER TO DRYVIT PUBLICATION DS217.
4. BACK FASTEN THROUGH STUD FLANGE INTO FEDDERLITE CHANNEL AS NOTED IN APPROVED STRUCTURAL DRAWINGS.

*The architecture, engineering, and design of the project using the Dryvit and Tremco products are the responsibility of the project's design professional. All products and systems must comply with local building codes and standards. This detail is for general information and guidance only and Dryvit and Tremco specifically disclaims any liability for the use of this detail. The project design professional determines, in its sole discretion, whether this detail or a functionally equivalent detail is best suited for the project. This detail is subject to change without notice. Contact Dryvit or Tremco to ensure you have the most recent version.*

**Fedderlite® Panel System**



Detail: Panel Vertical Joint - Back Fastened Method				File Name:	
Drawn by: HDE	Checked by: RB CW	Scale: NTS	Date: 9/28/2023	FL 08	
<a href="http://www.tremcocpg.com">www.tremcocpg.com</a>					

