

OPTION 1

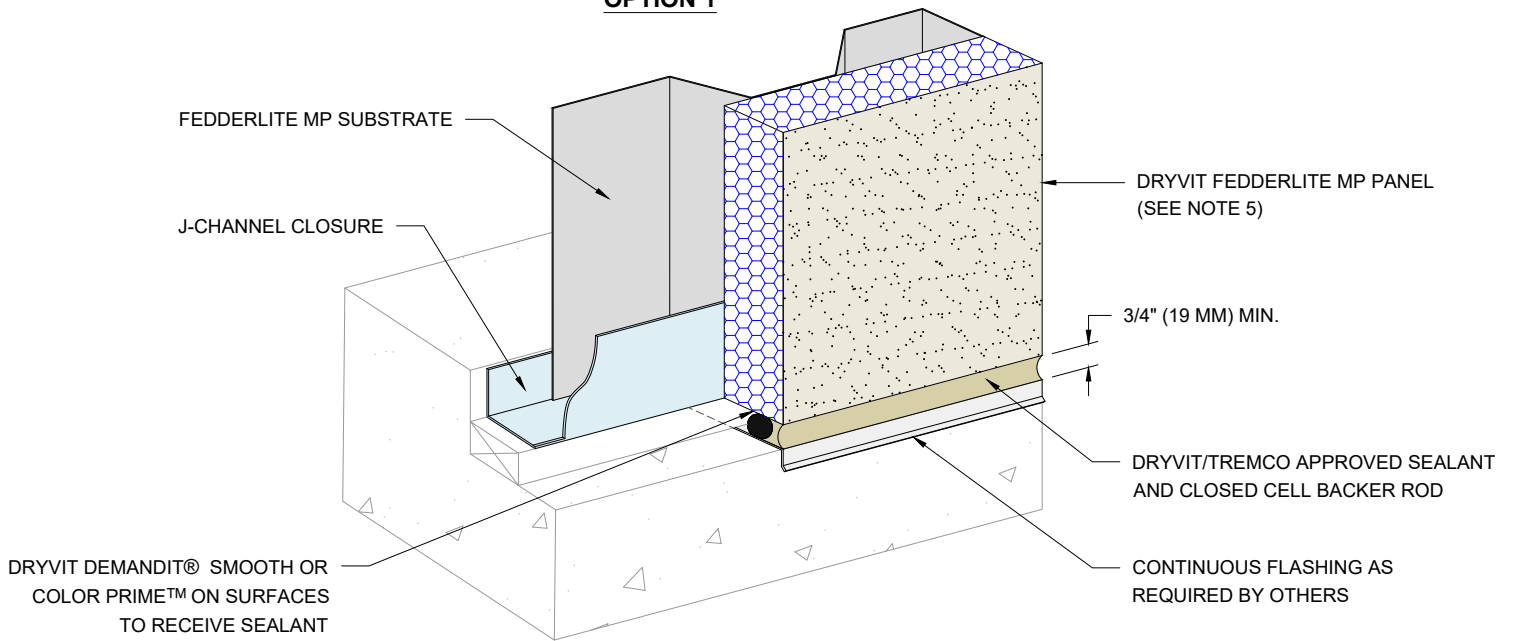

OPTION 2

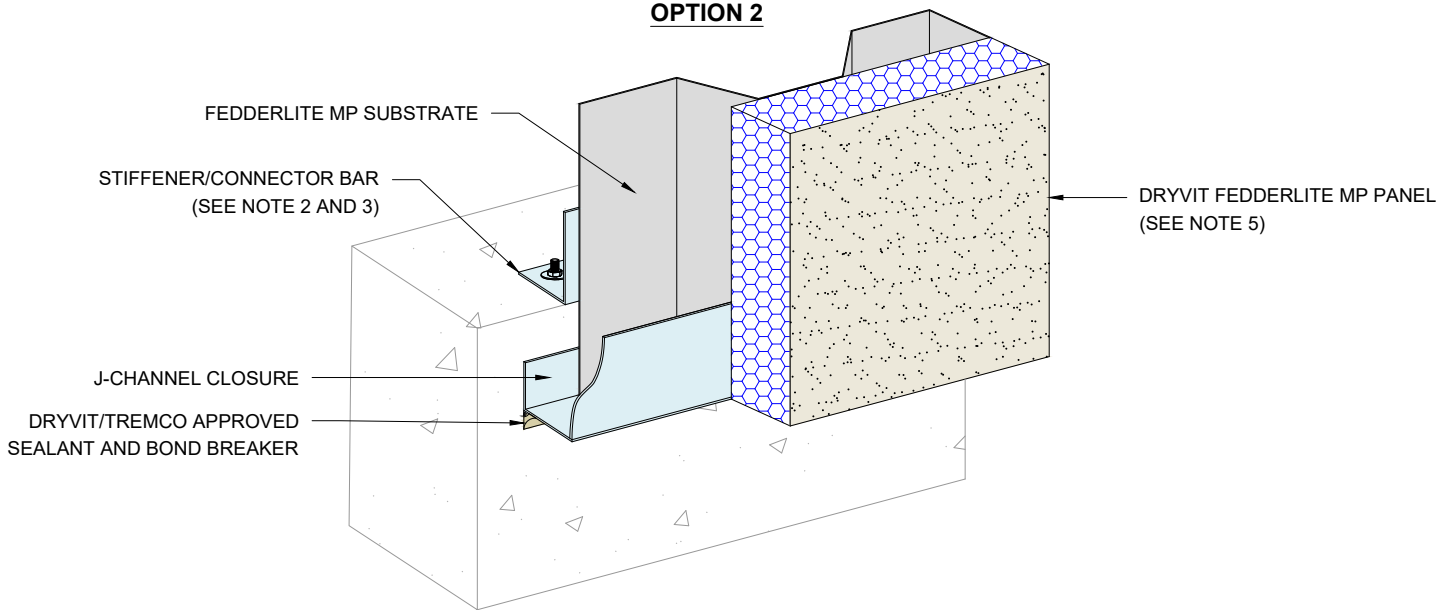



NOTES:

1. DRYVIT RECOMMENDS THAT GROUND FLOOR APPLICATIONS AND ALL FACADES EXPOSED TO ABNORMAL STRESS, HIGH TRAFFIC, OR DELIBERATE IMPACT HAVE THE BASE COAT REINFORCED WITH PANZER® MESH PRIOR TO STANDARD OR STANDARD PLUS MESH. LOCATION OF HIGH IMPACT ZONES SHOULD BE INDICATED ON CONTRACT DRAWINGS.
2. STRUCTURAL ELEMENTS PER DESIGN ENGINEER.
3. FASTENER DESIGN PER APPROVED ENGINEERED SHOP DRAWINGS.
4. ALL FEDDERLITE MP MATERIAL TO RECEIVE DRYVIT LAMINA SHALL BE CLEANED WITH A DEGREASING AGENT.
5. MAINTAIN 6" (152 MM) MINIMUM CLEARANCE FROM GRADE CONDITIONS.

The architecture, engineering, and design of the project using the Dryvit products are the responsibility of the project's design professional. All products and systems must comply with local building codes and standards. This detail is for general information and guidance only and Dryvit specifically disclaims any liability for the use of this detail. The project design professional determines, in its sole discretion, whether this detail or a functionally equivalent detail is best suited for the project. This detail is subject to change without notice. Contact Dryvit to ensure you have the most recent version.

Fedderlite® MP Panel System

 Dryvit Technical Support: 800-556-7752	Detail: Termination at Foundation				File Name:		 Construction Products Group
	Drawn by: EM	Checked by: RB	Scale: NTS	Date: 2/6/2023	FL MP - 09		
www.tremcocpg.com							